

Performance

Lift breakout force (ISO 14397-2)	48.80 kN
Lift capacity (ISO 14397-2)	36.90 kN
Tipping load, straight (ISO 14397-1)	3801 kg
Tipping load, articulated at 40° (ISO 14397-1)	3151 kg

Engine

Model	2.4L V2 BOBCAT ENGINE
Compliancy	STAGE V
Cooling	Liquid
Fuel	Diesel
Power at 2600RPM (ISO 14396):	50.7 kW

Weights

Operating weight, standard (ISO 6016)	5091 kg
Shipping weight, standard (ISO 6016)	4674 kg
Max front axle load	6000 kg
Max rear axle load	6000 kg

Hydraulic System

System Relief @ Quick Couplers	20.5 MPa
Auxiliary Std Flow	75.40 L/min
Auxiliary High Flow	103.50 L/min

Drive System

Main Drive	Proportionally regulated hydrostatic motor
Transmission	Hydrostatic with electronic regulation

Controls

Vehicle steering	Machine articulation via hydraulic steering with steering wheel
Travel Direction	Travel direction switch (F-N-R) on joysticks. Drive pedal in work and travel mode.
Machine hydraulics	Dual axis joystick for lift, tilt and auxiliary
Vehicle braking	Combination of integrated 6 wet brake disk in rear axle with hydrostatic braking effect provision

Dimensions

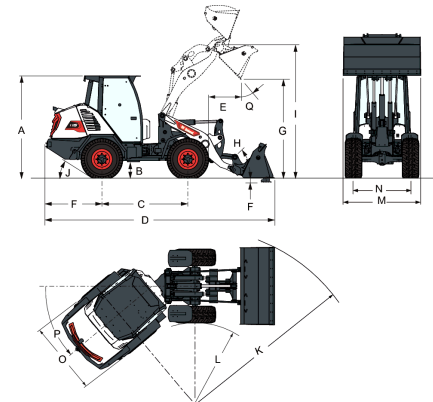

(A)	2497.7 mm	(J)	33.4°
(B)	427.0 mm	(K)	3829.8 mm
(C)	2100.0 mm	(L)	1985.6 mm
(D)	5452.7 mm	(M)	1900.0 mm
(E)	686.0 mm	(N)	1393.0 mm
(F)	100.0 mm	(O)	1800.0 mm
(G)	2507.5 mm	(P)	40.0°
(I)	3250.0 mm	(Q)	45.0°